

E96-408

Bailey®
infi 90

Instruction

Communication Termination Module (NICL01)

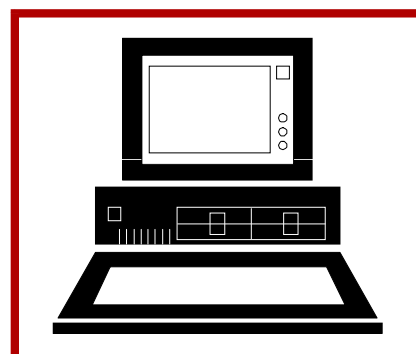
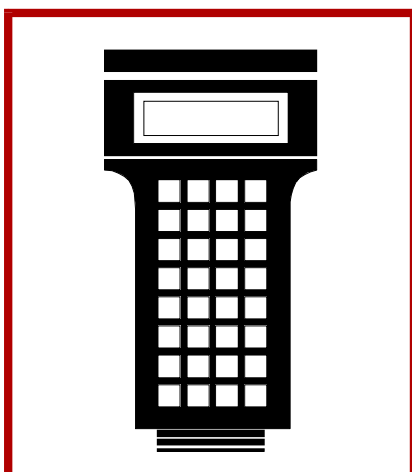
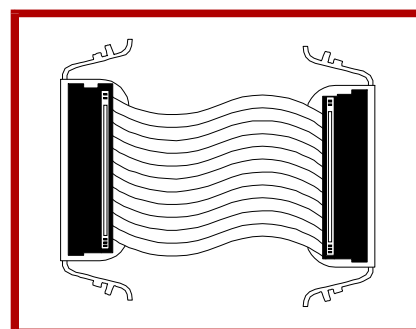
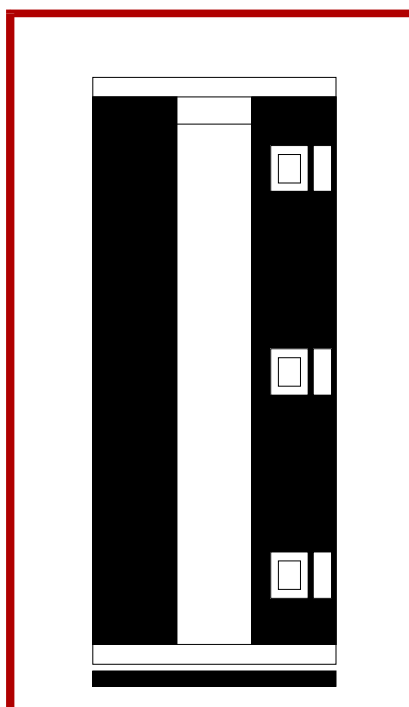
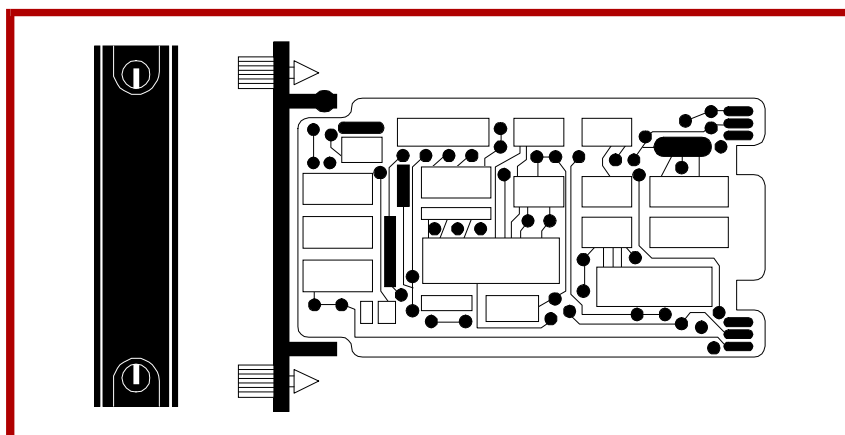
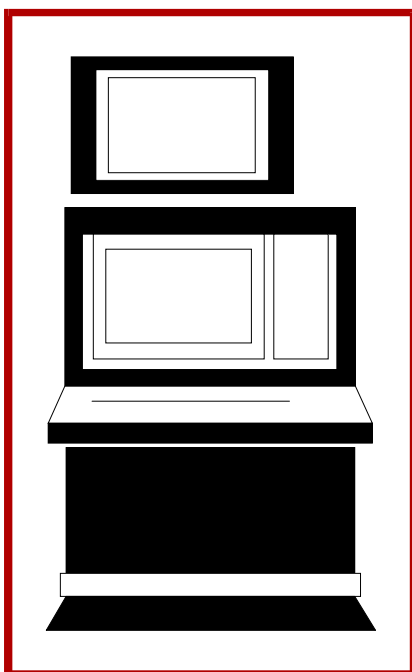

WARNING notices as used in this instruction apply to hazards or unsafe practices that could result in personal injury or death.

CAUTION notices apply to hazards or unsafe practices that could result in property damage.

NOTES highlight procedures and contain information that assists the operator in understanding the information contained in this instruction.

WARNING

INSTRUCTION MANUALS

DO NOT INSTALL, MAINTAIN, OR OPERATE THIS EQUIPMENT WITHOUT READING, UNDERSTANDING, AND FOLLOWING THE PROPER **Elsag Bailey** INSTRUCTIONS AND MANUALS; OTHERWISE, INJURY OR DAMAGE MAY RESULT.

RADIO FREQUENCY INTERFERENCE

MOST ELECTRONIC EQUIPMENT IS INFLUENCED BY RADIO FREQUENCY INTERFERENCE (RFI). CAUTION SHOULD BE EXERCISED WITH REGARD TO THE USE OF PORTABLE COMMUNICATIONS EQUIPMENT IN THE AREA AROUND SUCH EQUIPMENT. PRUDENT PRACTICE DICTATES THAT SIGNS SHOULD BE POSTED IN THE VICINITY OF THE EQUIPMENT CAUTIONING AGAINST THE USE OF PORTABLE COMMUNICATIONS EQUIPMENT.

POSSIBLE PROCESS UPSETS

MAINTENANCE MUST BE PERFORMED ONLY BY QUALIFIED PERSONNEL AND ONLY AFTER SECURING EQUIPMENT CONTROLLED BY THIS PRODUCT. ADJUSTING OR REMOVING THIS PRODUCT WHILE IT IS IN THE SYSTEM MAY UPSET THE PROCESS BEING CONTROLLED. SOME PROCESS UPSETS MAY CAUSE INJURY OR DAMAGE.

AVERTISSEMENT

MANUELS D'OPÉRATION

NE PAS METTRE EN PLACE, RÉPARER OU FAIRE FONCTIONNER L'ÉQUIPEMENT SANS AVOIR LU, COMPRIS ET SUIVI LES INSTRUCTIONS RÉGLEMENTAIRES DE **Elsag Bailey**. TOUTE NÉGLIGENCE À CET ÉGARD POURRAIT ÊTRE UNE CAUSE D'ACCIDENT OU DE DÉFAILLANCE DU MATÉRIEL.

PERTURBATIONS PAR FRÉQUENCE RADIO

LA PLUPART DES ÉQUIPEMENTS ÉLECTRONIQUES SONT SENSIBLES AUX PERTURBATIONS PAR FRÉQUENCE RADIO. DES PRÉCAUTIONS DEVRONT ÊTRE PRISES LORS DE L'UTILISATION DU MATÉRIEL DE COMMUNICATION PORTATIF. LA PRUDENCE EXIGE QUE LES PRÉCAUTIONS À PRENDRE DANS CE CAS SOIENT SIGNALÉES AUX ENDROITS VOULUS DANS VOTRE USINE.

PERTURBATIONS DU PROCÉDÉ

L'ENTRETIEN DOIT ÊTRE ASSURÉ PAR UNE PERSONNE QUALIFIÉE EN CONSIDÉRANT L'ASPECT SÉCURITAIRE DES ÉQUIPEMENTS CONTRÔLÉS PAR CE PRODUIT. L'AJUSTEMENT ET/OU L'EXTRACTION DE CE PRODUIT PEUT OCCASIONNER DES À-COUPS AU PROCÉDÉ CONTRÔLE LORSQU'IL EST INSÉRÉ DANS UNE SYSTÈME ACTIF. CES À-COUPS PEUVENT ÉGALEMENT OCCASIONNER DES BLESSURES OU DES DOMMAGES MATÉRIELS.

NOTICE

The information contained in this document is subject to change without notice.

Elsag Bailey, its affiliates, employees, and agents, and the authors and contributors to this publication specifically disclaim all liabilities and warranties, express and implied (including warranties of merchantability and fitness for a particular purpose), for the accuracy, currency, completeness, and/or reliability of the information contained herein and/or for the fitness for any particular use and/or for the performance of any material and/or equipment selected in whole or part with the user of/or in reliance upon information contained herein. Selection of materials and/or equipment is at the sole risk of the user of this publication.

This document contains proprietary information of Elsag Bailey, Elsag Bailey Process Automation, and is issued in strict confidence. Its use, or reproduction for use, for the reverse engineering, development or manufacture of hardware or software described herein is prohibited. No part of this document may be photocopied or reproduced without the prior written consent of Elsag Bailey.

Preface

The NICL01 terminates the connection of the INFI-NET[®] communication network to the Network Interface Slave Module (INNIS01) or Plant Loop to the Loop Interface Module (INLIM03). The NICL01 is designed to connect to communication loops of either twinaxial or coaxial cable.

This manual explains how to install and use the NICL01. It explains how to set the jumpers, install the cables, mount the termination module and lists maximum cable lengths for the communication loop.

List of Effective Pages

Total number of pages in this manual is 29, consisting of the following:

Page No.	Change Date
Preface	Original
List of Effective Pages	Original
iii through vi	Original
1-1 through 1-4	Original
2-1 through 2-7	Original
3-1	Original
4-1 through 4-2	Original
5-1	Original
A-1 through A-4	Original
B-1 through B-3	Original
Index-1	Original

When an update is received, insert the latest changed pages and dispose of the superseded pages.

NOTE: On an update page, the changed text or table is indicated by a vertical bar in the outer margin of the page adjacent to the changed area. A changed figure is indicated by a vertical bar in the outer margin next to the figure caption. The date the update was prepared will appear beside the page number.

Safety Summary

**GENERAL
WARNINGS**

Equipment Environment

All components, whether in transportation, operation, or storage must be in a noncorrosive environment.

Electrical Shock Hazard During Maintenance

Disconnect power or take precautions to ensure that contact with energized parts is avoided when servicing.

Special Handling

This module uses Electrostatic Sensitive Devices (ESD).

**SPECIFIC
CAUTIONS**

We strongly recommend that you turn cabinet power off before doing any termination module wiring. Failure to do so could result in equipment damage. Do not apply power until you verify all wire connections. (p. 2-7)

When removing and replacing an NICL01, all loop communication is lost while the termination module is removed from the loop. (p. 4-2)

Sommaire de Sécurité

**AVERTISSEMENTS
D'ORDRE
GÉNÉRAL****Environnement de l'équipement**

Ne pas soumettre les composants à une atmosphère corrosive lors du transport, de l'entreposage ou de l'utilisation.

Risques de chocs électriques lors de l'entretien

S'assurer de débrancher l'alimentation ou de prendre les précautions nécessaires à éviter tout contact avec des composants sous tension lors de l'entretien.

Précautions de Manutention

Ce module contient des composants sensibles aux décharges électro-statiques.

**ATTENTIONS
D'ORDRE
SPÉCIFIQUE**

Il est fortement recommandé, de débrancher l'alimentation électrique du cabinet avant d'effectuer toute connexion aux cartes de raccordement du châssis. Des dommages aux équipements pourraient survenir dans le cas contraire. Ne pas rebrancher l'alimentation avant que toutes les connexions aient été vérifiées. (p. 2-7)

Durant le démontage ou le remplacement d'une carte NICL01, toute communication avec le réseau est interrompue et ce pendant tout le temps où la carte est retirée du réseau. (p. 4-2)

Table of Contents

	<i>Page</i>
SECTION 1 - INTRODUCTION	1-1
INTRODUCTION	1-1
INTENDED USER	1-1
HARDWARE DESCRIPTION	1-1
FEATURES	1-1
INSTRUCTION CONTENT	1-1
HOW TO USE THIS MANUAL	1-2
NOMENCLATURE	1-3
GLOSSARY OF TERMS AND ABBREVIATIONS	1-3
REFERENCE DOCUMENTS	1-4
SPECIFICATIONS	1-4
SECTION 2 - INSTALLATION	2-1
INTRODUCTION	2-1
SPECIAL HANDLING	2-1
UNPACKING AND INSPECTION	2-2
PREPARING THE ICL FOR INSTALLATION	2-2
Installing the Fuse	2-3
Installing the Jumpers	2-3
INSTALLING THE TERMINATION MODULE	2-4
Installing the Termination Module Cables	2-4
Mounting the Termination Module	2-4
Communication Cable Installation	2-6
POWER WIRING	2-7
SECTION 3 - MAINTENANCE	3-1
INTRODUCTION	3-1
MAINTENANCE SCHEDULE	3-1
SECTION 4 - REPAIR/REPLACEMENT PROCEDURES	4-1
INTRODUCTION	4-1
FUSE REPLACEMENT	4-1
MODULE REPLACEMENT	4-1
SECTION 5 - SUPPORT SERVICES	5-1
INTRODUCTION	5-1
REPLACEMENT PARTS AND ORDERING INFORMATION	5-1
TRAINING	5-1
TECHNICAL DOCUMENTATION	5-1
APPENDIX A - NETWORK INTERFACE SLAVE MODULE CONFIGURATION (INNIS01)	A-1
INTRODUCTION	A-1
APPENDIX B - LOOP INTERFACE MODULE CONFIGURATION (INLIM03)	B-1
INTRODUCTION	B-1

List of Tables

<i>No.</i>	<i>Title</i>	<i>Page</i>
2-1.	ICL Circuit Boards Revision C Jumper Settings (for LIM or LIS Application)	2-3
2-2.	ICL Circuit Boards Revision D or Higher Jumper Settings	2-3
2-3.	ICL Cable Applications	2-5
3-1.	Maintenance Schedule.....	3-1
4-1.	Recommended Spare Parts List.....	4-1
A-1.	SW1 Node Addresses/SW2 Ring Numbers	A-2
A-2.	Loop Mode Switch (SW3) Settings	A-2
A-3.	Slave Address Switch (SW4) Settings	A-3
A-4.	Event Counters	A-3
A-5.	Error Counters	A-4
B-1.	LIM Event Counter Addresses (S1)	B-1
B-2.	LIM Error Counter Addresses (S1)	B-2
B-3.	PCU Address Settings (S2)	B-3

List of Figures

<i>No.</i>	<i>Title</i>	<i>Page</i>
1-1.	The NICL01 within a PCU on the INFI-NET Communication Highway	1-2
2-1.	NICL01 Connector Assignments and Jumper Locations, Revision D Boards	2-2
2-2.	ICL Cable Connections to the INLIM03 with Twinaxial Communication Loop	2-5
2-3.	ICL Cable Connections to the INNIS01 with Coaxial Communication Loop	2-6
A-1.	Network Interface Slave Module Switch and Jumper Locations	A-1
A-2.	User Configured Jumpers	A-4
B-1.	Loop Interface Module Component Locations	B-1

SECTION 1 - INTRODUCTION

INTRODUCTION

The Communication Termination Module (NICL01) provides a termination point for a Network Interface Slave Module (INNIS01) or a Loop Interface Module (INLIM03). The ICL can terminate either twinaxial or coaxial cable when connecting the NIS to INFI-NET or the LIM to Plant Loop. The cable type is selected through jumper settings on the ICL. Figure 1-1 shows an example of the NICL01 within a PCU on the INFI-NET communication highway.

INTENDED USER

Technicians should read the manual before installing the ICL. Do not put the ICL into operation until you read and understand this instruction.

HARDWARE DESCRIPTION

The ICL mounts in a Termination Mounting Unit (NTMU01/02), inside the INFI 90[®] cabinet. It is a printed circuit board that consists of:

- Terminal strips
- BNC connectors
- Passive electronic components
- Jumpers
- Fuse

FEATURES

The NICL01 provides connectors for both twinaxial cable and coaxial cable. Jumpers on the circuit board are set to match the impedance of the cable being used. The +24 VDC supplied to the board is fused, protecting the electronic circuitry on board.

INSTRUCTION CONTENT

This manual has five sections and two appendices.

- | | |
|---------------------|--|
| Introduction | Provides an overview of the ICL. |
| Installation | Explains physical installation, wiring and cable requirements, jumper settings, etc. |

[®] Registered trademark of Elsag Bailey Process Automation.

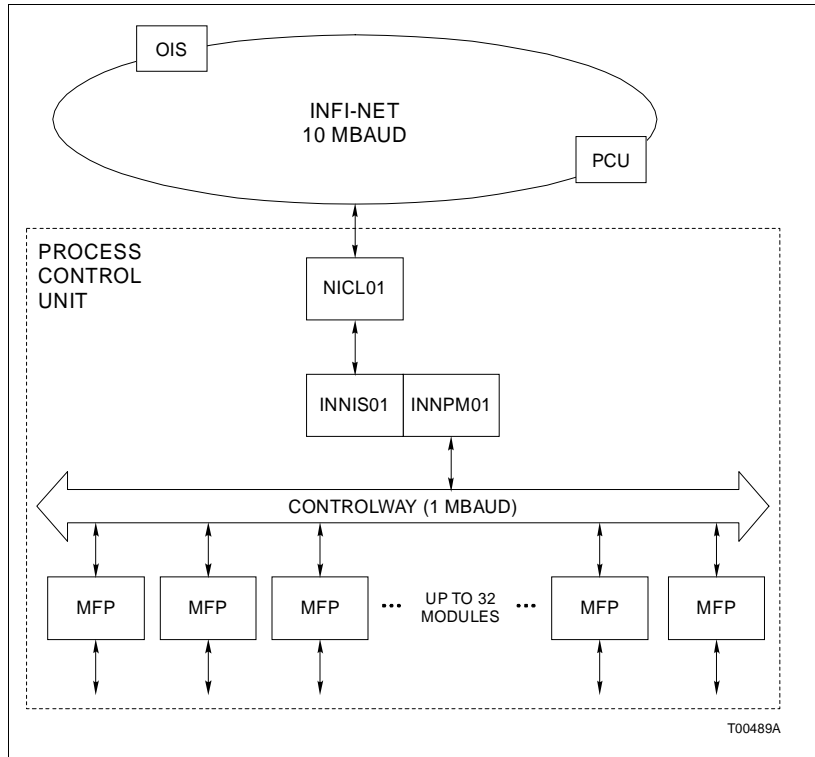

Figure 1-1. The NICL01 within a PCU on the INFI-NET Communication Highway

Maintenance Contains a maintenance schedule.

Repair/Replacement Procedures Explains how to replace the fuse or the module.

Support Services Explains training, documentation and how to order parts from Bailey Controls.

Appendices Discuss the modules that can use the ICL and provide a cross-reference of dipswitch and jumper settings for those modules.

HOW TO USE THIS MANUAL

Read this manual before installing the ICL. Do the installation steps in order. Do not operate the ICL until you complete all the steps in Section 2. Refer to the appendices for a quick reference guide to INNIS01 and INLIM03 module dipswitch and jumper settings.

NOMENCLATURE

Hardware	Nomenclature
Network Interface Slave Module	INNIS01
Loop Interface Module	INLIM03
Cables	
Twinaxial Communication Cable (PVC, stripped wire both ends)	NKPL03
(non-PVC, stripped wire both ends)	NKPL04
INFI-NET Adapter Cable (used with KCL cable)	NKTL01-3
Coaxial Communication Cable (PVC, with BNC connectors)	NKCL01
(non-PVC, with BNC connectors)	NKCL02
ICL to ICL Cable	NKTT01
ICL to LIM Cable (PVC)	NKLS04
(non-PVC)	NKLS14
ICL to NIS Cable (PVC)	NKLS02
(non-PVC)	NKLS12
Termination Mounting Unit (rear mount)	NTMU01
(front mount)	NTMU02

GLOSSARY OF TERMS AND ABBREVIATIONS

Term	Definition
Coaxial cable	A special type of communications cable that permits the transmission of data at high speed.
INFI-NET	Advanced data communication highway.
Plant Loop	Network 90 [®] data communication highway.
TM	Termination Module. Provides input/output connection between plant equipment and the INFI 90/Network 90 modules.
TMU	Termination Mounting Unit. A card cage that provides housing for INFI 90/Network 90 termination modules.
Twinaxial cable	A cable composed of two insulated conductors that are twisted together and are attached or bound together with a common covering.

® Registered trademark of Elsag Bailey Process Automation.

REFERENCE DOCUMENTS

Document No.	Document
I-E96-601	INFI-NET Communications Modules
I-E96-605	Bus Interface Module/Loop Interface Module

SPECIFICATIONS

Power Requirements:	
Voltage	24 VDC
Current	19.7 mA maximum, 15.8 mA typical
Mounting	Slides into a single slot in the termination mounting unit NTMU01/02.
Cooling Requirements	No cooling necessary when used in Bailey cabinets and operated within stated environmental limits.
Operating Temperature	0° to 70°C (32° to 158°F).
Relative Humidity	5% to 90% (± 5%) up to 55°C (131°F) noncondensing. 5% to 40% (± 5%) up to 70°C (158°F) noncondensing.
Air Quality	Bailey equipment should be operated and stored in a noncorrosive environment.
Certification	CSA certified as process control equipment for use in an ordinary (nonhazardous) location.

Specifications are subject to change without notice.

SECTION 2 - INSTALLATION

INTRODUCTION

This section explains how to install the communication termination module (NICL01). The installation procedure covers handling, jumper configuration, fuse installation, cable connection and physical installation.

SPECIAL HANDLING

Observe these steps when handling electronic circuitry:

NOTE: Always use Bailey's Field Static Kit (P/N 1948385A1 - consisting of wrist straps, ground cord assembly, and alligator clip) when working with the modules. The kit connects a technician and the static dissipative work surface to the same ground point to prevent damage to the modules by electrostatic discharge.

1. **Use Antistatic Bag.** Keep the modules in the antistatic bag until you are ready to install them in the system. Save the bag for future use.
2. **Ground Bags Before Opening.** Before opening a bag containing an assembly with CMOS devices, touch it to the equipment housing or a ground to equalize charges.
3. **Avoid Touching Circuitry.** Handle assemblies by the edges; avoid touching the circuitry.
4. **Avoid Partial Connection of CMOS Device.** Verify that all devices connected to the modules are properly grounded before using them.
5. **Ground Test Equipment.**
6. **Use an Antistatic Field Service Vacuum.** Remove dust from the module if necessary.
7. **Use a Grounded Wrist Strap.** Connect the wrist strap to the appropriate grounding plug on the power entry panel. The grounding plug on the power entry panel must be effectively connected to the earth grounding electrode system through the DC common bus.
8. **Do Not Use Lead Pencils to Set Dipswitches.** To avoid contamination of switch contacts that can result in unnecessary circuit board malfunction, do not use a lead pencil to set a dipswitch.

UNPACKING AND INSPECTION

1. Examine the termination module immediately for any shipping damage.
2. Notify the nearest Bailey Controls sales office of any damage.
3. File a claim for any damage with the transportation company that handled the shipment.
4. Use the original packing material or container to store the termination module.
5. Store the module in an environment of good air quality, free from temperature and moisture extremes.

PREPARING THE ICL FOR INSTALLATION

Before you mount the ICL in the termination mounting unit, check the fuse and jumpers. Jumper settings configure the termination module to match the impedance of the communication cable. These jumpers must be properly installed for the system to operate. Figure 2-1 shows the location of the fuse holder, jumpers, and connectors.

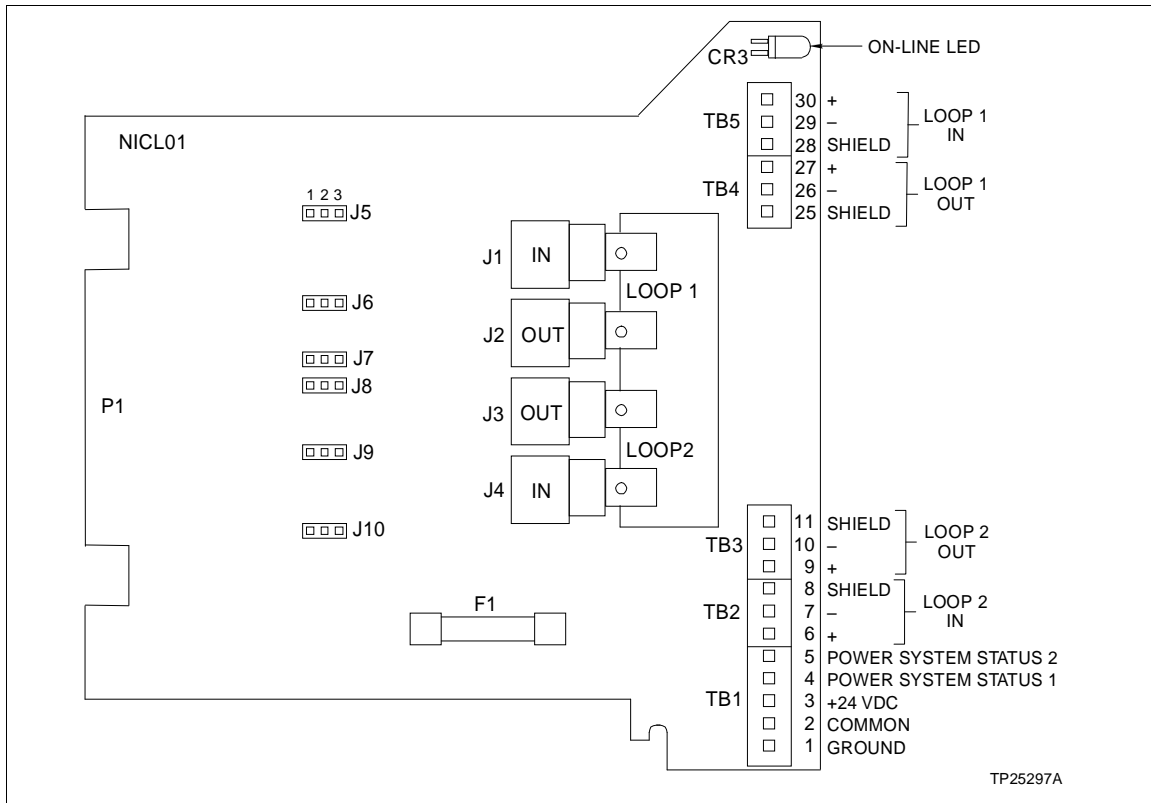

Figure 2-1. NICL01 Connector Assignments and Jumper Locations, Revision D Boards

Installing the Fuse

Bailey ships a 1.0 amp/250 volt fuse (Bailey P/N 194776A11001) with each ICL. Verify that the fuse is installed in the fuse holder marked F1. Figure 2-1 shows the location of the fuse holder on the ICL circuit board.

Installing the Jumpers

Install the jumpers to match the impedance of the communication cable. The proper jumper settings depend on the revision level of the termination module. To set the jumpers on termination modules that are revision A or B, follow the jumper settings silkscreened on the printed circuit board. Revision C termination modules have jumpers J5 - J12 set for LIS (regardless of whether an LIS or LIM is used), and J13 - J18 are set for the cable type used. Table 2-1 shows the jumper settings for revision C communication termination modules. Table 2-2 shows the jumper settings for communication termination modules revision D or higher. Install the jumpers before mounting the termination module in the termination mounting unit.

NOTE: The revision level of a circuit board is indicated by the next to the last digit of the alphanumeric assembly number silkscreened to the circuit board. For example, ASSY P/N 6636980D1 indicates a revision D circuit board).

Table 2-1. ICL Circuit Boards Revision C Jumper Settings (for LIM or LIS Application)

Jumper No.	Twinax	Coax
J5-J12		
J13-J18	 T00490A	

Table 2-2. ICL Circuit Boards Revision D or Higher Jumper Settings

Jumper No.	Twinax	Coax
J5-J10	 T00490A	

INSTALLING THE TERMINATION MODULE

If the fuse and jumpers are in place, the termination module is ready to install.

Installing the Termination Module Cables

Before mounting the termination module in the TMU, install the termination cables. Table 2-3 lists the cables, their application, connector assignments and length restrictions. Figures 2-2 and 2-3 show diagrams of cable connections to the LIM and NIS. To install the termination module cable:

1. Install the hooded end of the appropriate cable in the module mounting unit (MMU) backplane slot assigned to the LIM or NIS. Because of keyed connectors on the termination cable, it should easily snap into place when properly installed.

NOTE: If the LIM or NIS module is installed, pull the module away from the MMU backplane several inches. The card edge of the module must not come into contact with the card edge connector of the termination cable while installing the cable. After installing the cable, slide the module into the MMU so that the card edge sits within the card edge connector. Refer to the product instructions for the INLIM03 or INNIS01 for more information about the installation or removal of those modules.

2. Install the other end of the termination cable in the termination mounting unit (TMU) backplane slot assigned to the ICL. Because of keyed connectors on the termination cable, it should easily snap into place when properly installed.

Mounting the Termination Module

The termination module occupies one slot in the INFI 90 termination mounting unit.

NOTE: You can install the communication cable before or after mounting the TM. It may be easier for you to install the communication cable with the board lying on a flat work surface (near the cabinet). If so, install the cable before mounting it by following the steps under Communication Cable Installation. To mount the termination module:

1. Locate the slot in the TMU that is assigned to the ICL.
2. Inserting the TM card edge first, align the termination module with the guide rails in the TMU.
3. Slide the module into its slot. If the communication cable and power wiring have been installed, fully insert the TM until it seats in the cable connector at the rear of the TMU.
4. Snap on the front cover of the termination module.

5. If the communication cable or power wiring have not been installed, let the termination module hang out the front of the TMU several inches. This will allow room to install the communication cable and power wiring. After the cables are installed, fully insert the TM until it seats in the cable connector at the rear of the TMU.

Table 2-3. ICL Cable Applications

Nomenclature/Description	Application	Connector	Maximum Length Meters (Feet)
NKLS04 (PVC) NKLS14 (non-PVC) Termination cable	Connects the ICL to the INLIM03	P1	61 (200)
NKLS02 (PVC) NKLS12 (non-PVC) Termination cable	Connects the ICL to the INNIS01	P1	25 (82)
NKCL01 (PVC) NKCL02 (non-PVC) Coaxial communication cable INFI-NET or Plant Loop	Connects individual drops on the communication loop	Must connect to an NKTL01 on each end	2000 (6562), INFI-NET at 10 Mbaud 4000 (13120), INFI-NET at 2 Mbaud 2000 (6562), Plant Loop
NKPL03 (PVC) NKPL04 (non-PVC) Twinaxial communication cable INFI-NET or Plant Loop	Connects individual drops on the communication loop	TB1 for Loop 1 TB2 for Loop 2	1000 (3281), INFI-NET at 10 Mbaud 2000 (6562), INFI-NET at 2 Mbaud 2000 (6562), Plant Loop
NKTL01-3 Coaxial adapter cable	Adapts and connects the NKCL01 to the ICL	J1, J2 for Loop 1 J3, J4 for Loop 2	1 (3)
NKTT01 Coaxial cable	Connects an ICL to an ICL	J1 to J4	800 (2624)

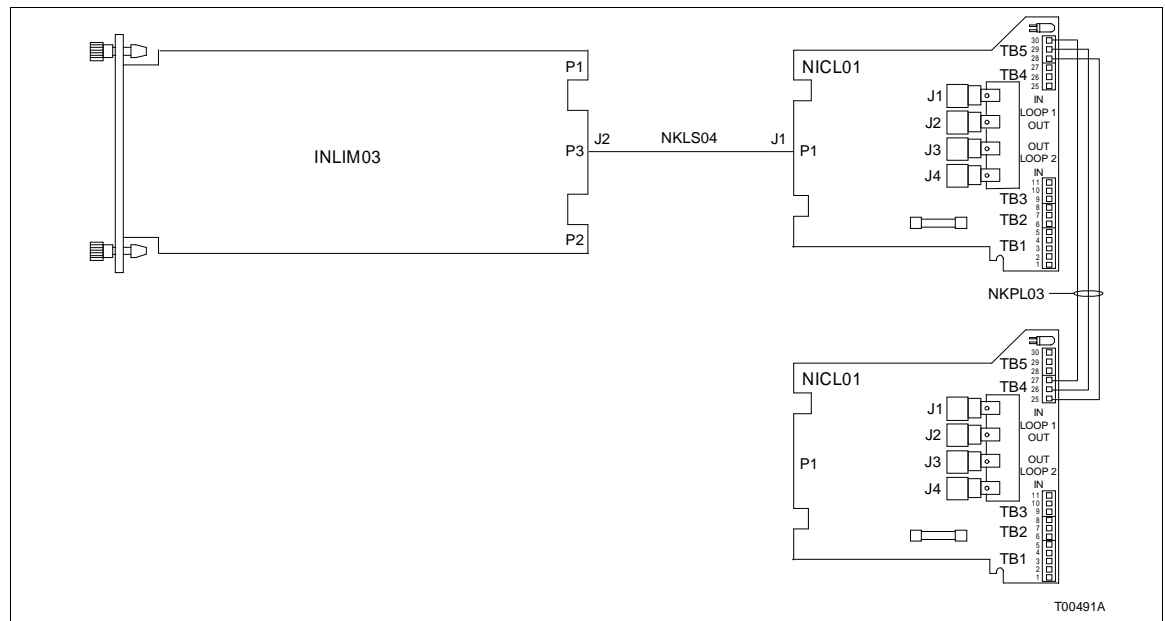
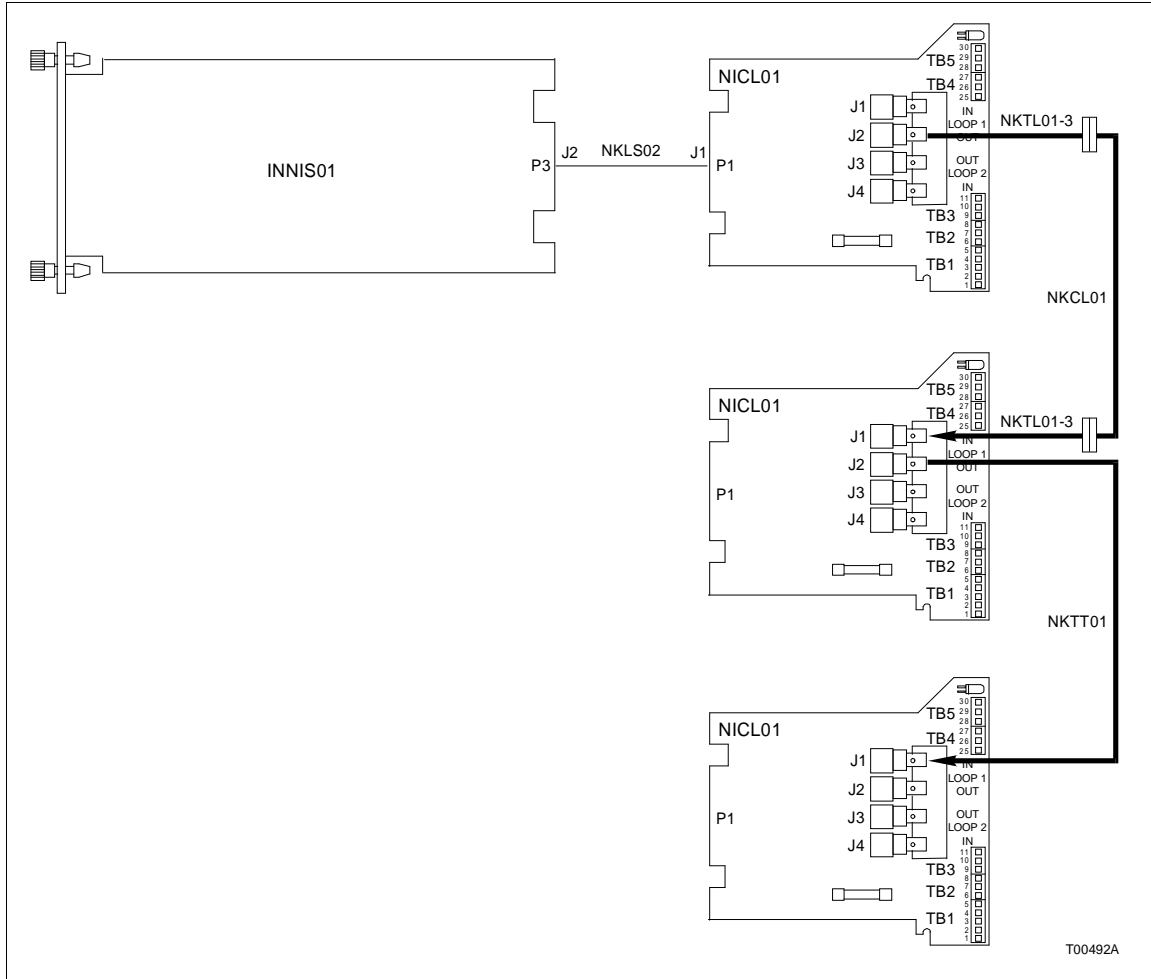

Figure 2-2. ICL Cable Connections to the INLIM03 with Twinaxial Communication Loop



T00492A

Figure 2-3. ICL Cable Connections to the INNIS01 with Coaxial Communication Loop

Communication Cable Installation

The communication cable connects the ICL to INFI-NET, Plant Loop or to another ICL. Table 2-3 lists the communication cables, their application, connector assignments and length restrictions. Figures 2-2 and 2-3 show diagrams of cable connections to the LIM and NIS. To install the communication cable:

1. If using coaxial cable, connect the cable to the termination module at the appropriate (loop 1 or 2) BNC connector. The BNC connector assignments are marked on the circuit board and are shown in Figure 2-1.
2. If using twinaxial cable, connect the cable to the termination module at the terminal blocks, TB2 and TB3 or TB4 and TB5. The terminal assignments appear on the circuit board silkscreen and are shown in Figure 2-1.

POWER WIRING**CAUTION**

We strongly recommend that you turn cabinet power off before doing any termination module wiring. Failure to do so could result in equipment damage. Do not apply power until you verify all wire connections.

ATTENTION

Il est fortement recommande, de debrancher l'alimentation electrique du cabinet avant d'effectuer toute connexion aux cartes de raccordement du chassis. Des dommages aux equipements pourraient survenir dans le cas contraire. Ne pas rebrancher l'alimentation avant que toutes les connexions aient ete verifiees.

There is one terminal block (TB1) that connects to +24 VDC, system common and ground. Figure 2-1 shows their location on the ICL circuit board. To connect power to the termination module in a system using modular power supplies:

1. Connect an 18 AWG wire from the +24 VDC faston of the TMU power bus bar to the TB1 terminal marked +24 VDC on the ICL.
2. Connect an 18 AWG wire from the I/O common on the TMU power bus bar to the TB1 terminal marked I/O common on the ICL.
3. Connect an 18 AWG green/yellow wire from the cabinet chassis ground point to the TB1 terminal marked ground on the ICL.

The NICL01 is ready for operation if:

1. The fuse is installed.
2. The jumpers are installed for the type of communication cable being used.
3. The circuit board is mounted in the termination mounting unit.
4. All required cables are connected to the termination module.
5. Power is connected and is applied to the termination module.

SECTION 3 - MAINTENANCE

INTRODUCTION

The communication termination module requires minimal maintenance. Doing the tasks in Table 3-1 will provide long, trouble free service. Please note that only qualified personnel should perform maintenance.

MAINTENANCE SCHEDULE

Table 3-1 is the maintenance schedule. These tasks are to be performed at the specified intervals.

Table 3-1. Maintenance Schedule

Task	Interval
Clean and tighten all cable and power connections.	Every 6 months or during plant shutdown, whichever occurs first.
Use a static safe vacuum cleaner to remove dust from: Termination modules. Termination mounting unit.	

SECTION 4 - REPAIR/REPLACEMENT PROCEDURES

INTRODUCTION

Repair procedures are limited to fuse and termination module (TM) replacement. If the ICL fails, remove it and replace it with another one.

FUSE REPLACEMENT

If the fuse (F1) opens, replace it with a fuse having an equivalent rating. Table 4-1 describes the fuse and lists its Bailey part number. To replace a fuse:

1. Turn off power to the termination module.
2. Pull on the front cover of the termination module to remove it.
3. Remove the termination module from the termination mounting unit (TMU).
4. Remove the blown fuse from its holder (F1).
5. Replace the blown fuse with a 1.0 amp, 250 volt fuse.
6. Return the termination module to its assigned slot in the TMU.
7. Replace the front cover to the termination module.
8. Turn on power to the termination module.

Table 4-1. Recommended Spare Parts List

Description	Part Number
Fuse, 1.0A/250V	Bailey P/N 194776A11001

MODULE REPLACEMENT

If you determine that the ICL is faulty, replace it with a new one. **Do not** try to repair the module; replacing components may affect the module performance and certification. Table 4-1 contains a list of recommended spare parts.

CAUTION

When removing and replacing an NICL01, all loop communication is lost while the termination module is removed from the loop.

ATTENTION

Durant le demontage ou le remplacement d'une carte NICL01, toute communication avec le reseau est interrompue et ce pendant tout le temps ou la carte est retiree du reseau.

When replacing a termination module, verify that:

1. The proper fuse has been installed on the replacement termination module.
2. All jumper settings on the replacement termination module are the same as the failed TM.

NOTE: Turn off power to the cabinet before removing the +24 VDC and ground connection to the ICL.

Follow Steps 1 through 7 to replace the ICL termination unit.

1. Remove the front cover and pull the TM out of the TMU so that the communication and power cables are accessible.
2. Verify that the cabinet power is off, then disconnect the +24 VDC and ground wiring from TB1 of the termination module. Mark the cables according to their terminal assignment as you remove them.
3. Disconnect the coaxial or twinaxial cable from the termination module. Mark the cables according to their terminal assignments as you remove them.
4. Remove the faulty termination module.
5. Align the circuit board of the replacement TM with the guide rails of its assigned slot within the termination mounting unit.
6. Push the circuit board into the TMU, but allow the TM to partially hang out the front of the TMU. Allow enough room at the front of the replacement TM to reconnect the communication cabling and +24 VDC power wiring.
7. After the communication and power cabling have been replaced, slide the TM into the TMU until its card edge seats in the card edge connector of the termination module cable on the backplane of the TMU.
8. Replace the front cover to the termination module.
9. Turn on power to the termination module.

SECTION 5 - SUPPORT SERVICES

INTRODUCTION

Bailey Controls is ready to help in the use and repair of its products. Contact your nearest sales office to make requests for sales, applications, installation, repair, overhaul and maintenance contract services.

REPLACEMENT PARTS AND ORDERING INFORMATION

When making repairs at your facility, order replacement parts from a Bailey sales office. Provide this information:

1. Part description, part number and quantity.
2. Model and serial numbers (if applicable).
3. Bailey instruction manual number, page number and reference figure that identifies the part.

When you order standard parts from Bailey Controls, use part numbers and descriptions from the Recommended Spare Parts Lists. You must order parts without commercial descriptions from the nearest Bailey Controls sales office.

TRAINING

Bailey Controls has a modern training facility available for training your personnel. On-site training is also available. Contact a Bailey Controls sales office for specific information and scheduling.

TECHNICAL DOCUMENTATION

You can obtain additional copies of this manual from the nearest Bailey sales office at a reasonable charge.

APPENDIX A - NETWORK INTERFACE SLAVE MODULE CONFIGURATION (INNIS01)

INTRODUCTION

The Network Interface Slave Module (INNIS01) uses the NICL01 to terminate its connection to an INFI-NET ring. A termination cable (NKLS02) connects the NIS to the ICL. The ICL provides a place to connect either coaxial or twinaxial cable from the communication loop. This appendix contains figures and tables that show the dipswitch and jumper locations on the NIS and their settings. This information is provided as a quick reference guide for personnel installing the NICL01. Figure A-1 shows the dipswitch locations on the NIS circuit board. Table A-1 shows how to set the NIS node address and ring number using dipswitches SW1 and SW2. Table A-2 lists the loop mode dipswitch settings (SW3). Table A-3 shows examples of slave address settings (SW4). Tables A-4 and A-5 list event and error counter settings respectively, using dipswitch SW4. Figure A-2 shows the jumper settings (J1 through J6) that set the communication rate of the receiver analog circuit on the NIS. Refer to the INFI-NET Communications Modules Instruction for more detailed installation and configuration information.

NOTE: For all dipswitches:
OPEN or OFF position = logic 1
CLOSED or ON position = logic 0

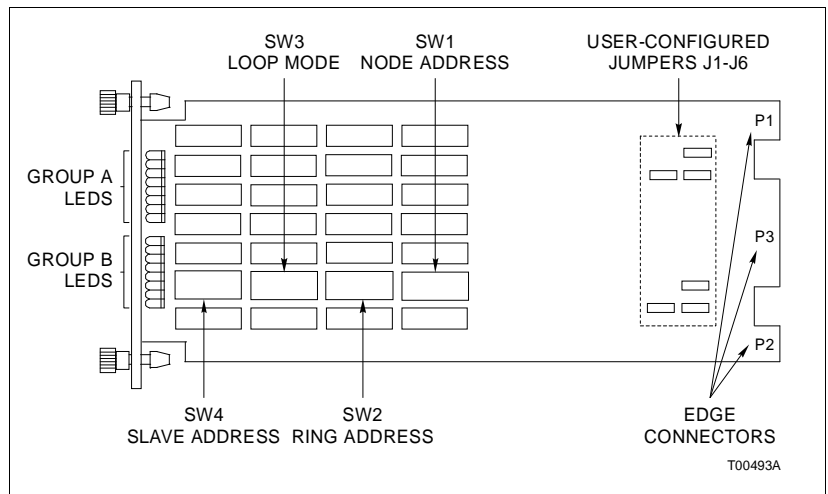

Figure A-1. Network Interface Slave Module Switch and Jumper Locations

Table A-1. SW1 Node Addresses/SW2 Ring Numbers

Example Settings									
Address	Switch Position	1	2	3	4	5	6	7	8
Example	Binary Value	128	64	32	16	8	4	2	1
1		0	0	0	0	0	0	0	1
64		0	1	0	0	0	0	0	0
250		1	1	1	1	1	0	1	0

Table A-2. Loop Mode Switch (SW3) Settings

Pole	Setting	Function
1	1	IPL/IIL (Bridge or Gateway).
	0	PCU/ICI.
2	1	ROM Checksum Enabled
	0	ROM Checksum Disabled.
3	1	Test mode; no timeout for handshake failure.
	0	Normal operating mode.
4 ¹	0	Normal operating mode.
	1	Busy NAK all Loop Messages.
5 ¹	0	LED display as defined by SW4.
	1	Will toggle on/off group A LEDs if loop 1 is idle or shorted. Will toggle on/off group B LEDs if loop 2 is idle or shorted. If both loops are good, normal LED display as defined by SW4.
6 ¹	0	Normal operating mode.
	1	Diagnostic mode.
7/8	0/0	10 MHz INFI-NET mode.
	0/1	2 MHz INFI-NET mode.
	1/0	Not used.
	1/1	500 kHz Plant Loop mode.

NOTE: 1. Applies to Revision B and later version ROMs. For Revision A ROMs, poles 4 through 6 must be set to 0.

Table A-3. Slave Address Switch (SW4) Settings

Example Settings			
Address	Pole		
	1	2	3
00	0	0	0
03	0	1	1
07	1	1	1

Table A-4. Event Counters

SW4 Position 4 5 6 7 8	Hex	Description
0 0 0 0 0	00	Number of timer interrupts.
0 1 0 0 1	09	Number of multicast messages received, excluding originated messages.
0 1 0 1 0	0A	Number of multicast destinations received.
0 1 0 1 1	0B	Number of time-sync messages received, excluding originated messages.
0 1 1 0 0	0C	Number of broadcast messages received, excluding originated messages.
0 1 1 0 1	0D	Number of NIS poll messages received, excluding originated messages.
0 1 1 1 0	0E	Number of NIS poll messages acknowledged (ACK) by this node.
0 1 1 1 1	0F	Number of NIS poll messages busy-not acknowledged (BSY-NAK) by this node.
1 0 0 0 0	10	Number of messages transmitted, total loop traffic.
1 0 0 0 1	11	Number of messages received and forwarded by this node.
1 0 0 1 0	12	Number of messages originated by this node, including retries.
1 0 0 1 1	13	Number of message retries originated by this node.
1 0 1 0 0	14	Number of transmitted message watchdog expirations.
1 0 1 0 1	15	Number of messages put into receive buffer and retained.
1 0 1 1 0	16	Number of bytes originated by this node, including retries.
1 0 1 1 1	17	Number of bytes received and forwarded by this node.
1 1 0 0 0	18	Number of Slave Expander Bus to NIS handshakes.
1 1 0 0 1	19	Number of Slave Expander Bus Message to Transmit Buffer signals.
1 1 0 1 0	1A	Number of Slave Expander Slave Bus PCU-status requests.

Table A-4. Event Counters (continued)

SW4 Position 4 5 6 7 8	Hex	Description
1 1 0 1 1	1B	Number of Slave Expander Bus NIS-status requests.
1 1 1 0 0	1C	Number of Slave Expander Bus interrupts with invalid status.
1 1 1 0 1	1D	Number of transmit buffer realignments due to invalid contents.
1 1 1 1 0	1E	Number of receive buffer realignments.
1 1 1 1 1	1F	Number of status buffer realignments.

Table A-5. Error Counters

SW4 Position 4 5 6 7 8	Hex	Description
0 0 0 0 1	01	Number of channel 1 receive errors.
0 0 0 1 0	02	Number of channel 2 receive errors.
0 0 0 1 1	03	Number of transmitter errors.
0 0 1 0 0	04	Number of messages lost to receive queue overflow.
0 0 1 0 1	05	Number of messages dumped with circulation count errors.
0 0 1 1 0	06	Number of messages dumped with destination count or message-type errors.
0 0 1 1 1	07	Number of messages dumped with source-state errors.
0 1 0 0 0	08	Number of messages dumped with source-sequence mismatch.

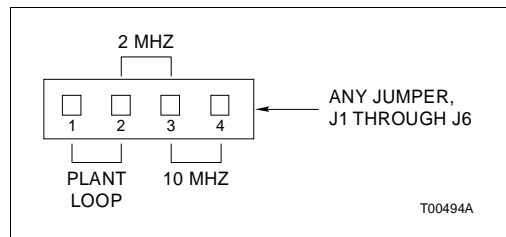

Figure A-2. User Configured Jumpers

APPENDIX B - LOOP INTERFACE MODULE CONFIGURATION (INLIM03)

INTRODUCTION

The Loop Interface Module (INLIM03) uses the NICL01 to terminate its connection to Plant Loop. A termination cable (NKLS04) connects the LIM to the ICL. The ICL provides a place to connect either coaxial or twinaxial cable from the communication loop. This appendix contains figures and tables that show the dipswitch locations on the LIM and their settings and is provided as a quick reference for personnel installing the NICL01. Figure B-1 shows the dipswitch locations on the LIM circuit board. Tables B-1 and B-2 list the event counter and error counter addresses for dipswitch S1. Table B-3 lists PCU addresses set by dipswitch S2. Refer to the INLIM03 instruction for more detailed installation and configuration information.

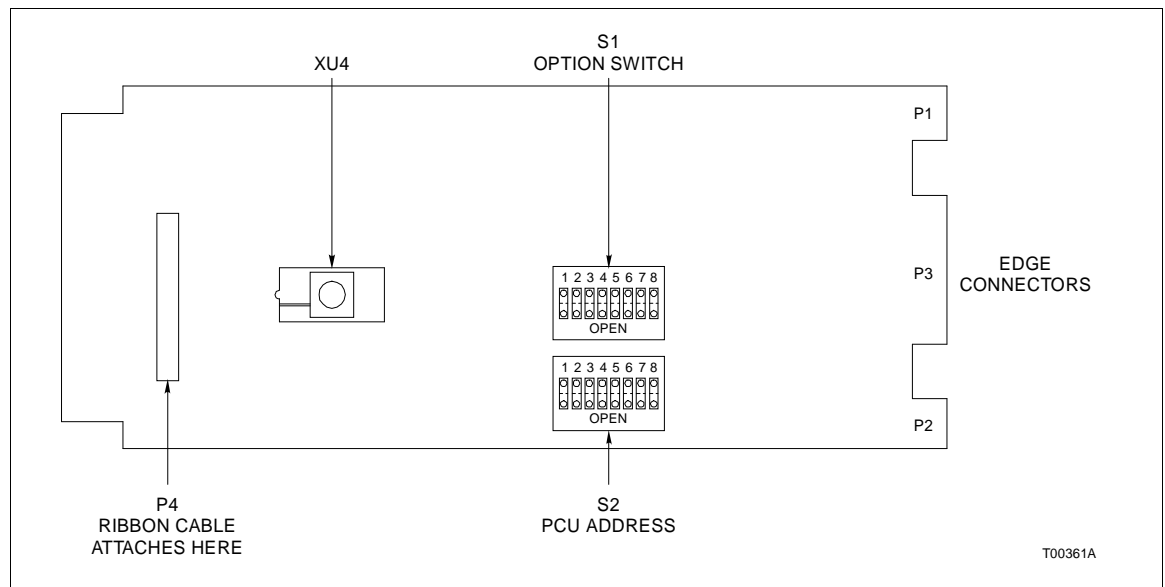

Figure B-1. Loop Interface Module Component Locations

Table B-1. LIM Event Counter Addresses (S1)

Counter Address	Hex Address	Switch Positions (Binary Address)	Description
		1 2 3 4 5 6 7 8	
48	30	0 0 1 1 0 0 0 0	Total messages transmitted, including forwarding.
49	31	0 0 1 1 0 0 0 1	Transmit retries.
50	32	0 0 1 1 0 0 1 0	Composite BIM Receive/Transmit 4 bits each. Receive is viewed at the top LED.
51	33	0 0 1 1 0 0 1 1	Messages taken from the BIM transmit buffer.

Table B-1. LIM Event Counter Addresses (S1) (continued)

Counter Address	Hex Address	Switch Positions	Description
		(Binary Address) 1 2 3 4 5 6 7 8	
52	34	0 0 1 1 0 1 0 0	Messages stored in BIM receive buffer.
53	35	0 0 1 1 0 1 0 1	Interrupt Requests (IRQs) sent by BIM.
54	36	0 0 1 1 0 1 1 0	High Priority (HP) messages transmitted.
55	37	0 0 1 1 0 1 1 1	High Priority messages received.
56	38	0 0 1 1 1 0 0 0	Commands issued by the BIM.
57	39	0 0 1 1 1 0 0 1	Missed BIM transmit requests.
58	3A	0 0 1 1 1 0 1 0	Spurious Non-Maskable Interrupts (NMI) caused by "address present."
59	3B	0 0 1 1 1 0 1 1	HEY (request for an interrupt; generated by BIM) message sent.
60	3C	0 0 1 1 1 1 0 0	Messages discarded when the destination is off-line.
61	3D	0 0 1 1 1 1 0 1	HEY time expirations.
62	3E	0 0 1 1 1 1 1 0	Passes through the IDLE level (2 bytes wide).

Table B-2. LIM Error Counter Addresses (S1)

Counter Address	Hex Address	Switch Positions	Description
		(Binary Address) 1 2 3 4 5 6 7 8	
64	40	0 1 0 0 0 0 0 0	Composite error count developed every hand-shake period - the summation of all other error counters.
65	41	0 1 0 0 0 0 0 1	Unresolved NMI interrupts.
66	42	0 1 0 0 0 0 1 0	Unresolved IRQ interrupts.
67	43	0 1 0 0 0 0 1 1	Unresolved timer interrupts.
68	44	0 1 0 0 0 1 0 0	Queue overflow message losses.
69	45	0 1 0 0 0 1 0 1	Checksum failures.
70	46	0 1 0 0 0 1 1 0	Unresolved BIM IRQs.
71	47	0 1 0 0 0 1 1 1	Sequence errors.
72	48	0 1 0 0 1 0 0 0	Header CRC/OVRN errors.
73	49	0 1 0 0 1 0 0 1	Data CRC/OVRN errors.
74	4A	0 1 0 0 1 0 1 0	Messages developing data CRC errors en route to destination.
75	4B	0 1 0 0 1 0 1 1	Transmission failures.
76	4C	0 1 0 0 1 1 0 0	Watchdog timer expirations.
77	4D	0 1 0 0 1 1 0 1	Data length errors.
78	4E	0 1 0 0 1 1 1 0	Loop - 1 Receive (RCV) failure.
79	4F	0 1 0 0 1 1 1 1	Loop - 2 Receive failures.
80	50	0 1 0 1 0 0 0 0	Loop - 1 Transmit (TX) failure.
81	51	0 1 0 1 0 0 0 1	Loop - 2 Transmit failures.

Table B-3. PCU Address Settings (S2)

PCU Address	Switch Number 1 2 3 4 5 6 7 8	PCU Address	Switch Number 1 2 3 4 5 6 7 8
1	0 0 0 0 0 0 0 1	33	0 0 1 0 0 0 0 1
2	0 0 0 0 0 0 1 0	34	0 0 1 0 0 0 1 0
3	0 0 0 0 0 0 1 1	35	0 0 1 0 0 0 1 1
4	0 0 0 0 0 1 0 0	36	0 0 1 0 0 1 0 0
5	0 0 0 0 0 1 0 1	37	0 0 1 0 0 1 0 1
6	0 0 0 0 0 1 1 0	38	0 0 1 0 0 1 1 0
7	0 0 0 0 0 1 1 1	39	0 0 1 0 0 1 1 1
8	0 0 0 0 1 0 0 0	40	0 0 1 0 1 0 0 0
9	0 0 0 0 1 0 0 1	41	0 0 1 0 1 0 0 1
10	0 0 0 0 1 0 1 0	42	0 0 1 0 1 0 1 0
11	0 0 0 0 1 0 1 1	43	0 0 1 0 1 0 1 1
12	0 0 0 0 1 1 0 0	44	0 0 1 0 1 1 0 0
13	0 0 0 0 1 1 0 1	45	0 0 1 0 1 1 0 1
14	0 0 0 0 1 1 1 0	46	0 0 1 0 1 1 1 0
15	0 0 0 0 1 1 1 1	47	0 0 1 0 1 1 1 1
16	0 0 0 1 0 0 0 0	48	0 0 1 1 0 0 0 0
17	0 0 0 1 0 0 0 1	49	0 0 1 1 0 0 0 1
18	0 0 0 1 0 0 1 0	50	0 0 1 1 0 0 1 0
19	0 0 0 1 0 0 1 1	51	0 0 1 1 0 0 1 1
20	0 0 0 1 0 1 0 0	52	0 0 1 1 0 1 0 0
21	0 0 0 1 0 1 0 1	53	0 0 1 1 0 1 0 1
22	0 0 0 1 0 1 1 0	54	0 0 1 1 0 1 1 0
23	0 0 0 1 0 1 1 1	55	0 0 1 1 0 1 1 1
24	0 0 0 1 1 0 0 0	56	0 0 1 1 1 0 0 0
25	0 0 0 1 1 0 0 1	57	0 0 1 1 1 0 0 1
26	0 0 0 1 1 0 1 0	58	0 0 1 1 1 0 1 0
27	0 0 0 1 1 0 1 1	59	0 0 1 1 1 0 1 1
28	0 0 0 1 1 1 0 0	60	0 0 1 1 1 1 0 0
29	0 0 0 1 1 1 0 1	61	0 0 1 1 1 1 0 1
30	0 0 0 1 1 1 1 0	62	0 0 1 1 1 1 1 0
31	0 0 0 1 1 1 1 1	63	0 0 1 1 1 1 1 1
32	0 0 1 0 0 0 0 0		

Index

C		M	
Cable lengths	2-5	Maintenance	3-1
Certification	1-4	Mounting	2-4
Circuit board revision.....	2-3		
Coaxial cable.....	1-3, 2-5	N	
D		Nomenclature.....	1-3
Documentation	5-1		
F		O	
Fuse rating	4-1	Ordering information	5-1
Fuse replacement.....	4-1		
G		P	
Glossary of terms and abbreviations.....	1-3	Power requirements.....	1-4
H		Power wiring	2-7
Hardware description	1-1		
I		R	
INLIM03	B-1	Reference documents.....	1-4
INNIS01	A-1	Repair procedure	4-1
Installation			
Communication cable	2-6	S	
Fuse.....	2-3	Spare parts	4-1
Jumper.....	2-3	Special handling.....	2-1
Mounting.....	2-4	Specifications.....	1-4
Power wiring	2-7		
Termination cable	2-4	T	
Intended user	1-1	Termination module cables.....	2-5
		TM replacement	4-1
		Training	5-1
		Twinaxial cable	1-3, 2-5

Visit *Elsag Bailey* on the World Wide Web at <http://www.bailey.com>

Our worldwide staff of professionals is ready to meet *your* needs for process automation.
For the location nearest you, please contact the appropriate regional office.

AMERICAS

29801 Euclid Avenue
Wickliffe, Ohio USA 44092
Telephone 1-216-585-8500
Telefax 1-216-585-8756

ASIA/PACIFIC

152 Beach Road
Gateway East #20-04
Singapore 189721
Telephone 65-391-0800
Telefax 65-292-9011

EUROPE, AFRICA, MIDDLE EAST

Via Puccini 2
16154 Genoa, Italy
Telephone 39-10-6582-943
Telefax 39-10-6582-941

GERMANY

Graefstrasse 97
D-60487 Frankfurt Main
Germany
Telephone 49-69-799-0
Telefax 49-69-799-2406